

P2S-03-L1

2-WAY DROP-IN HIGH POWER DIVIDER

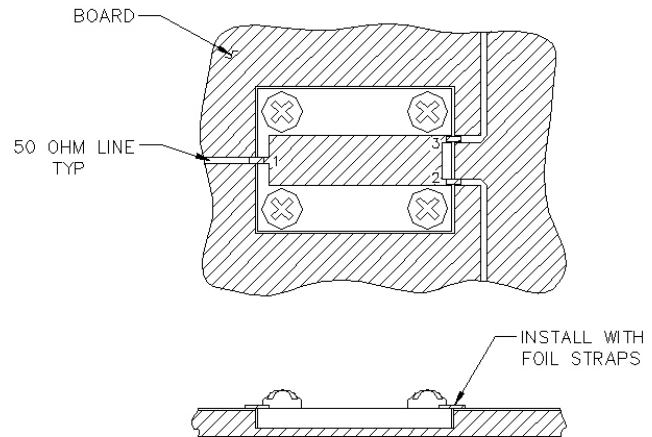
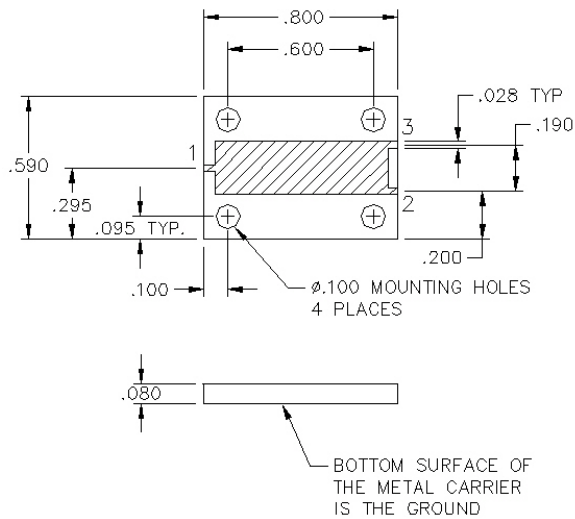

TYPICAL APPLICATION
UNIT SHOWN PLACED
IN CUTOUT OF BOARD

SPECIFICATIONS

Name:	P2S-03-L1
Frequency Range:	2-4 GHz
Insertion Loss:	0.4 dB max.
Isolation:	20 dB min.
Amplitude Balance:	0.3 dB max.
Phase Balance:	3° max.
VSWR:	1.40:1 max.
Input Power:	1 watts max.
Package Type:	Drop-In

Input power is specified for load VSWR better than 1.20:1.

PORT CONFIGURATION

Input:	1
Output:	2, 3
Ground:	Case

This is a commercial off the shelf (COTS) product.
For an equivalent product that meets DFARS materials compliance, contact sales.
All specifications are subject to change without notice at any time. Rev: 190404

