

BP-10-S

BI-PHASE MODULATOR

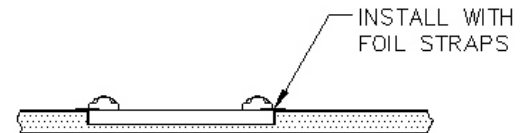
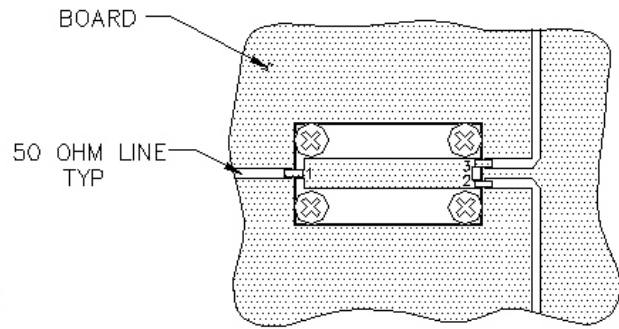
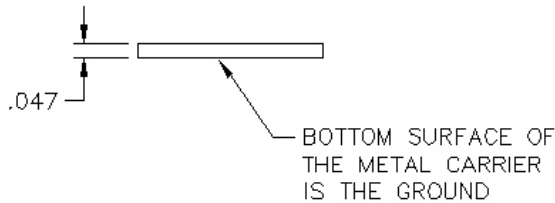
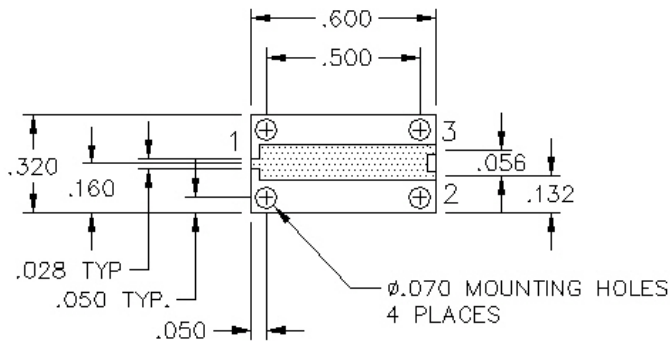

TYPICAL APPLICATION
UNIT SHOWN PLACED
IN CUTOUT OF BOARD

SPECIFICATIONS

Name:	BP-10-S
Frequency Range:	6000-12000 MHz
Insertion Loss:	4.5 dB max.
Input Power:	+10 dBm max.
Amplitude Balance:	0.5 dB max.
Phase Balance:	5° max.
VSWR:	2.00:1 max.
Carrier Suppression:	25 dBc Typ.
Package Type:	Drop-In

Control currents are ± 20 mA DC.

PORT CONFIGURATION

Input:	1
Output:	3
D - 1:	2
Ground:	Housing